

**PHILIPS
ADVANCE**

**High Pressure
Sodium
Lamp Ballast**

**Catalog Number 72C8185
For 150W S55
60 Hz HX-HPF
Status: Active**

DIMENSIONS AND DATA

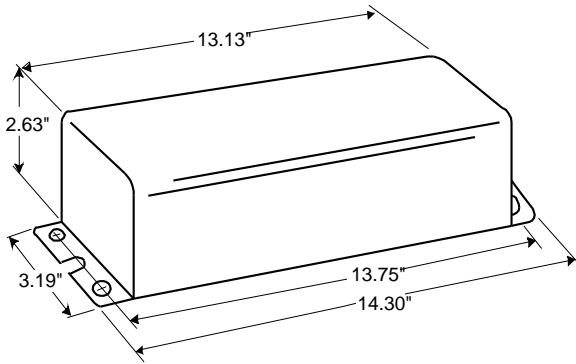

INPUT VOLTS	120	277			
CIRCUIT TYPE	HX-HPF				
POWER FACTOR (min)	90%				
REGULATION					
Line Volts	±5%				
Lamp Watts	WITHIN TRAPEZOID				
LINE CURRENT (Amps)					
Operating.....	1.65	0.72			
Open Circuit.....	2.25	1.00			
Starting.....	2.55	1.15			
UL TEMPERATURE RATINGS					
Insulation Class	A (105°C)				
Coil Temperature Code	1029		A	A	
MIN. AMBIENT STARTING TEMP.	-40°F or -40°C				
NOM. OPEN CIRCUIT VOLTAGE	120				
INPUT VOLTAGE AT LAMP DROPOUT.....	96	222			
INPUT WATTS	185				
RECOMMENDED FUSE (Amps).....	8	4			
CORE and COIL					
Dimension (A)					
Dimension (B)	14				
Weight (lbs.)	12"				
Lead Lengths					
CAPACITOR REQUIREMENT					
Microfarads					
Volts (min.)					
Fault Current Withstand (amps)					
60 Hz TEST PROCEDURES (Refer to Philips Lighting Electronics N.A. TEST Procedure for HID Ballasts - Form 127)					
High Potential Test (Volts)	1600				
1 minute	2000				
2 seconds	110-130				
Open Circuit Voltage Test (Volts)					
Short-Circuit Current Test (Amps)	4.00-5.00				
Secondary Current					
Input Current.....	2.50-	1.10-	-	-	-
	3.70	1.60			

Capacitor:

The capacitor is included as part of the potted assembly.



Wiring Diagram:

All Lead Lengths 12"

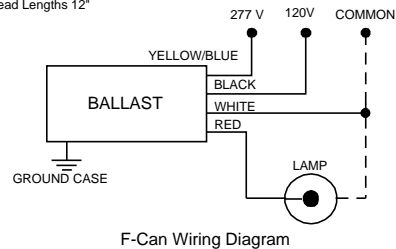

Ignitor: IN CAN

The ignitor is included as part of the potted assembly.

Ballast to Lamp Distance (BTL) = 5 feet
Temp Rating: 90°C

Typical Ordering Information

(please call Philips Lighting Electronics N.A. for suffix availability)

Order Suffix

Description

Data is based upon tests performed by Philips Lighting Electronics N.A. in a controlled environment and is representative of relative performance. Actual performance can vary depending on operating conditions. Specifications are subject to change without notice.

PHILIPS LIGHTING ELECTRONICS N.A.

10275 WEST HIGGINS ROAD · ROSEMONT, IL 60018

Tel: 800-322-2086 · Fax: 888-423-1882 · www.philips.com/advance

Customer Support/Technical Service: 800-372-3331 · OEM Support: 866-915-5886

Revised: 09/03/99